MUSICAL FIDELITY

R O U N D T A B L E Record Player



The Round Table is a high quality but competitive turntable solution.

It features a high quality low resonance 9" pickup arm, and magnetic anti skating compensation, and vertical bearings are ABEC7 ball bearings. These bearings are steel tipped and housed in Zirconium with rubber damping, similar in principle to shock protection used in high quality watches. Adjustable counter weight, vertical tracking height and magnetic anti-skate mechanism allows different cartridges to be used, as desired.

The Round Table plinth and platter are made from low resonance material and feet have vibration-isolation properties. The mass of the round table has also been carefully tuned so the centre is located at the bearing location.

The unit is supplied mostly assembled and an Audio Technica 95E cartridge has also been factory fitted.

Round Table Record Player

TOP VIEW

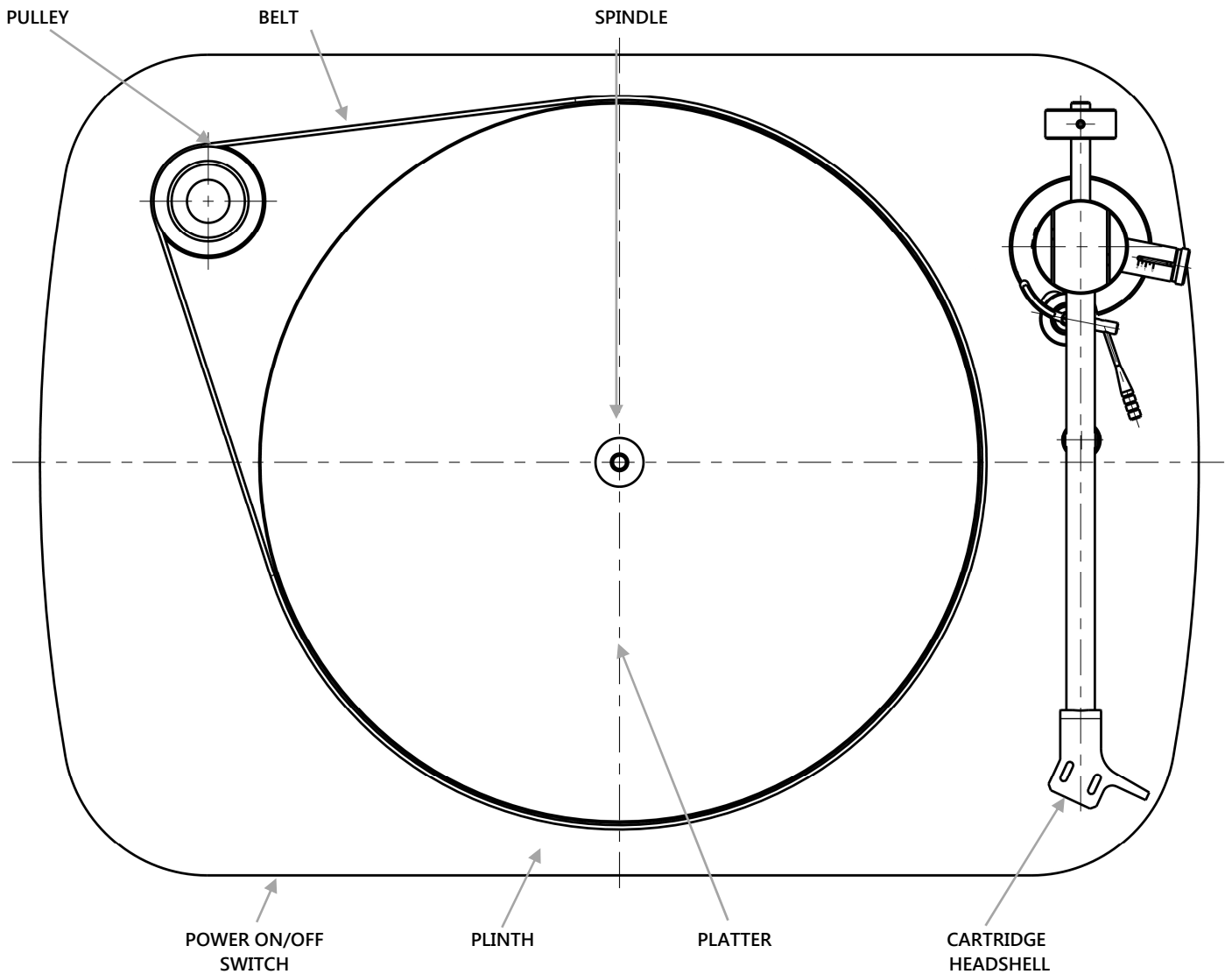

REAR VIEW

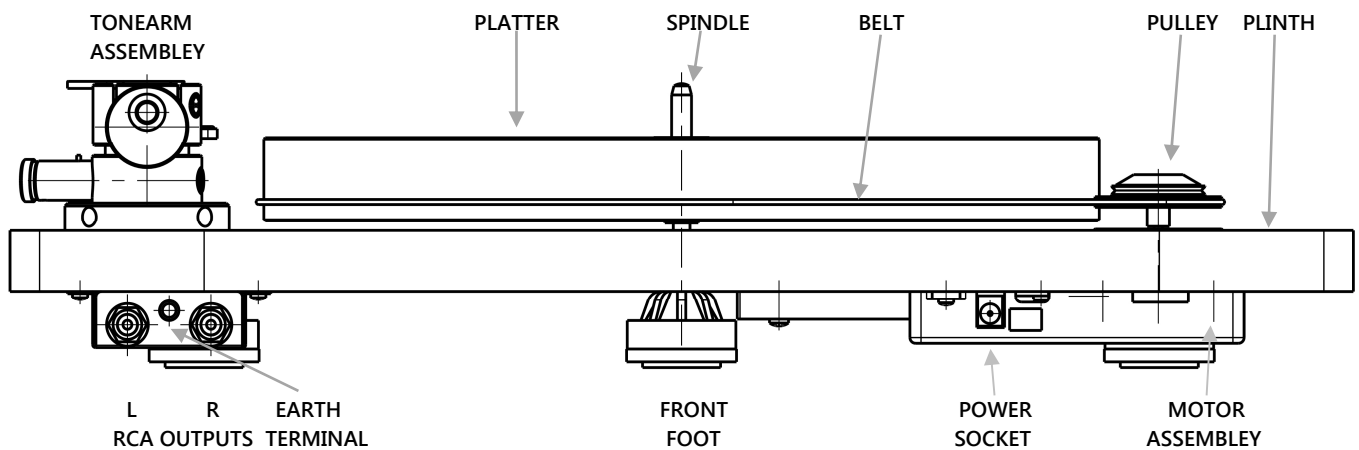

Round Table record player

Unpacking And Setting Up

Place box right way up on floor and ensure designated area where record player is to be used is clear, level and stable. Try to route any nearby significant current carrying (e.g. mains and speaker cables) as far away as possible.

Open up top of box carefully, taking care not to damage contents inside. Lift out covering and top packaging block to allow access to plinth/tonerarm assembly. Carefully lift this assembly out and place on the designated area.

Ensure unit is level and placed where it cannot be accidentally knocked. Check ON/OFF switch is in OFF position.

Remove plinth support packaging to gain access to platter below. Remove from packing and locate the 'lower portion' of the spindle (longer and square-cut). Carefully locate lower spindle into brass ring in centre of plinth and lower the platter until it is fully seated. Make sure platter spins smoothly by pushing it gently in a clockwise direction.

Note tonearm and cartridge are factory pre-set, so do not make any adjustments to them, unless fitting another cartridge!

Please keep all packing and the box in a safe place. These may be required for moving the unit elsewhere, and will ensure the unit's safe transport.

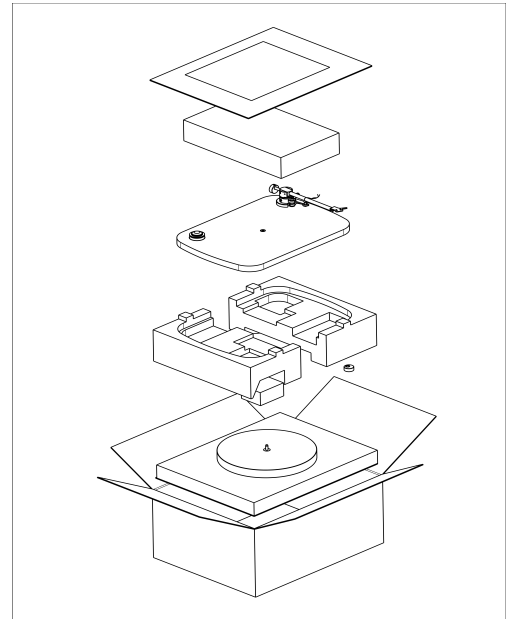

Fitting The Belt

White cotton gloves are provided to wear whilst handling the belt. The belt should be handled with care and must not be over-stretched, nor be contaminated with grease or sweat. These will affect performance and lifespan of the belt.

Initially set belt on pulley according to type of record normally played, see picture below.

PULLEY information

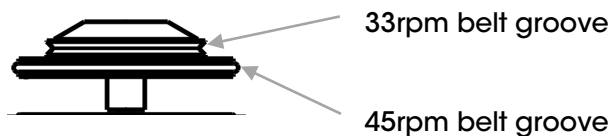

Position and hold the belt on the chosen pulley groove and pass belt around platter until it is fully encompassing both. Spin the turntable slowly clockwise, several turns, to allow the belt to gain optimum position on the platter. The belt should end up more or less parallel to the surface of the plinth.

Belt position on pulley may be changed at any time to accommodate different record sizes and speeds. Ensure platter is completely stationary before attempting to change belt position! A plastic speed change tool is additionally provided to help change belt position without touching it.

Power Adaptor

A mains power adaptor is supplied with different pin attachments to suit various mains sockets. Choose correct pin attachment for local mains and slide on to the contacts on the mains power supply case, in the direction indicated by "LOCK" on the attachment. A small click should be heard when the attachment locks into place. The power supply is now ready to use.

To change the socket type, press square button in centre of attachment and move attachment in position indicated by "unlock" on the attachment. The pin attachment should then slide off the power supply case. Plug power supply into wall and record player.

Round Table Record Player

Supplied Cartridge Counter Weight Setup

Locate counterweight and loosen screw with the 1.5mm (thin) hex Allen key. Slide counterweight halfway down counter balance support rod (see next page), making sure screw stays uppermost. Remove felt mat temporarily, and place plastic stylus pressure gauge on platter by tonearm. Place tonearm on the gauge with needle on the mN scale point at 20mN (2 grams).

Set the counter weight so the gauge rests horizontal with surface of the platter. Once the correct position is found, carefully tighten the counterweight screw without moving the counterweight. Once tightened, check the weight again, to make sure nothing has moved.

Set anti-skate control (see previous page) by twisting thumbscrew at its end. Set anti-skate control so pointer indicates 2.0g – same as used for tracking weight - on its scale.

Remove pressure gauge, replace mat on platter and place tonearm back in its rest.

Amplifier Connections

This turntable requires an amplifier with dedicated phono amplifier either built in or a separate phono amplifier unit. Line level inputs such as CD, AUX or TUNER are NOT suitable for phono cartridges.

Make sure the amplifier to be connected is switched OFF. This is to prevent loud noises getting through to your loudspeakers.

Connect the supplied lead starting at the turntable end. Connect the earth then left and right lead connections paying attention to match the colours of the plugs to the sockets. This helps reduce wiring errors and fault finding. Repeat this process at the amplifier end phono inputs, again checking wire colours against sockets. Depending on manufacturer, the "left" phono input socket may be black or white in colour. This is no cause for concern, connect the left lead to the left input socket regardless.

Keep the turntable power wires and any other mains cables present as far away from the cartridge output leads as possible.

The earth wire amplifier end is provided to connect to earthing post on the back of the amplifier, if required. Some setups will hum less with earths connected, others will perform better without.

Some experimentation may be required to get optimal performance.

First Use

Locate and place felt mat onto platter. This helps to reduce record slip and isolate needle from vibrations from the surroundings. Remove tonearm transport lock (red twist-tie) and cartridge stylus guard. Switch on record player using ON/OFF switch and check platter spins smoothly.

Switch on Phono stage, if present, or amplifier, checking volume is set to a low listening level.

Select PHONO or corresponding input on amplifier,

Place a record over the platter spindle and onto the platter mat. A plastic puck is provided for singles if required.

Use tonearm lift lever to raise tonearm from arm rest. Gently push the tonearm so the needle is over the start groove of the record. Use the lever to gently lower the needle onto the record. Once the tonearm is fully lowered turn up the volume to a comfortable listening level and enjoy listening.

Once side has finished, use lever once again to raise the tonearm and gently push it back to the tonearm rest and clip into place. Turn record over or chose a different one.

Do not leave record player playing the end loop for long periods, this causes wear to the needle.

Maintenance And Cleaning

Fit needle cover when not in use and make sure the arm is fully clipped into its rest.

Remove belt during long periods of inactivity to prevent uneven stretching.

Do not use dry cloth to clean unit as this will generate static charges and attract more dust - use a lightly dampened antistatic cloth to remove dust or light marks.

Do not allow cleaning agents to get onto rubber belt, as this could cause damage.

Round Table record player

Tonearm Assembly

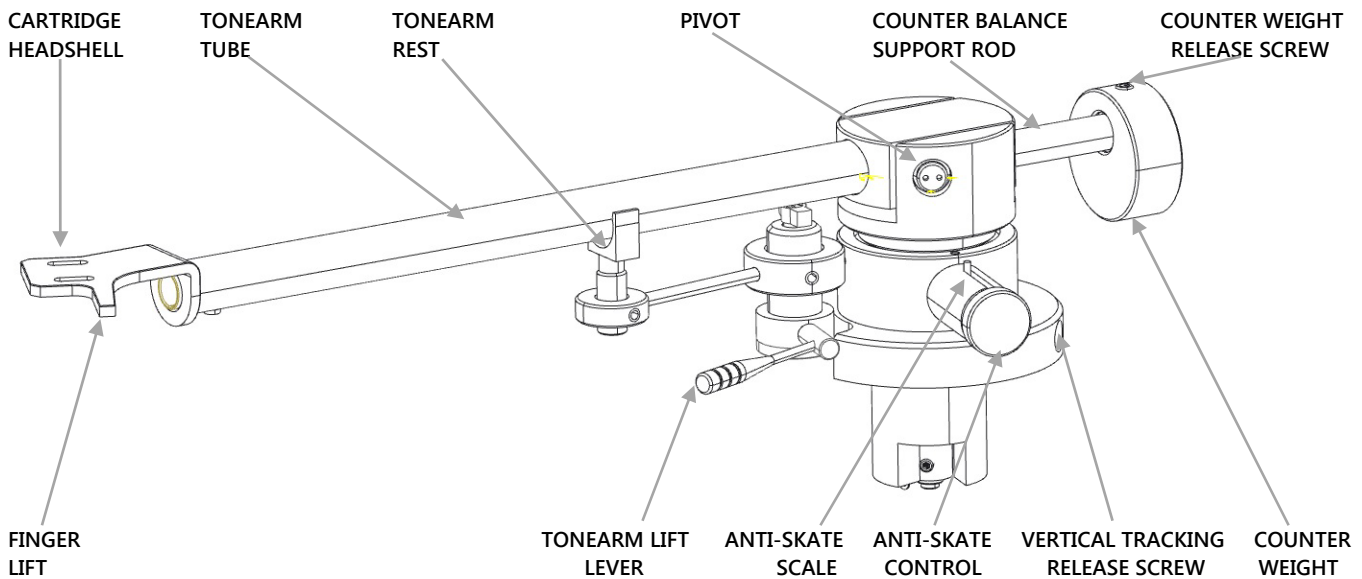

Changing Cartridge

Please note this information is for guidance only and is not required if using the factory installed cartridge. Do not tamper with factory settings if unit is to remain within specs published. If in doubt, please consult dealer for assistance.

Cartridge wiring follows:

WHITE	L+	LEFT CHANNEL POSITIVE
BLUE	L-	LEFT CHANNEL NEGATIVE
RED	R+	RIGHT CHANNEL POSITIVE
GREEN	R-	RIGHT CHANNEL NEGATIVE

Note: Incorrect cartridge wiring can cause considerable loss of signal, or inter channel phase shift (distinct lack of bass). Please be sure to consult cartridge manufacturers' instructions for corresponding connections on the cartridge. Do not remove cartridge guard until cartridge installation is complete.

Switch off amplifier and turntable!

Place tonearm into arm rest so it is secured. Remove old cartridge (if present) carefully taking care not to pull the delicate tonearm wires.

Store old cartridge in a safe place, with needle guard reinstated where possible.

Check new cartridge wiring instructions against wiring information above. Connect new cartridge accordingly. Once wiring is complete, attach cartridge to head shell, making sure front face of cartridge is in line with the front face of the head shell. The cartridge protractor on the white plastic gauge may also be used at this stage to help obtain even better alignment. Once alignment is complete, tighten cartridge/head shell screws and remove cartridge needle guard.

Round Table Record Player

Cartridge Counter Weight Adjustment

Loosen counterweight screw with the 1.5mm (thin) hex Allen key to counterweight moves easily. Slide counterweight to halfway down counter balance support rod, making sure screw stays uppermost.

Remove felt mat and place plastic stylus pressure gauge on platter by tonearm. Place tonearm on the gauge with needle on the mN scale point as follows:

10mN - 1.0 grams
15mN - 1.5 grams
20mN - 2.0 grams

Set the counter weight so the gauge rests horizontal and parallel with the surface of the platter. Once the correct position is found, carefully tighten the counterweight screw without moving the counterweight.

Once tightened, check the weight again, to make sure nothing has moved.

Set anti-skate control (see previous page) by twisting thumbscrew at its end. Set anti-skate control so pointer indicates the same value as used for tracking weight on its scale.

Vertical Tracking adjustment

Some cartridges have a larger assembly and it may be necessary to lift the tonearm overall to maintain correct operating position. This can be adjusted by loosening the vertical tracking adjust screw (see previous page) using the 3mm (thick) Allen key. The whole arm pivot and assembly can then be raised or lowered accordingly. Adjust height so tonearm is parallel to the record surface. Take care not to allow stylus to slip sideways

CAUTION: Do not over tighten the screw as this could deform the arm pillar. Finger tight is tight enough.

Supplied cartridge (Audio Technica AT95E) specifications

Cartridge type	Moving Magnet
Frequency Response	20 - 20,000 Hz
Channel Separation	20 dB at 1 kHz
Channel Balance	2.0dB
Tracking Force	1.5-2.5g
Vertical Tracking Angle	20°
Recommended Load Impedance	47,000 ohms
Output Voltage	3.5 mV (mV at 1 kHz, 5 cm/sec)
Stylus Shape	Elliptical
Stylus Construction	Bonded Round Shank
Mount	Half-inch
Weight	5.7g
Replacement Stylus	ATN95E

Round Table record player

Typical specifications

Nominal speed	33/45 rpm, outside belt drive system, manual speed change	
Speed Variance	33rpm: $\pm 0.30\%$, 45rpm: $\pm 0.20\%$	
Wow and flutter	33rpm: $\pm 0.10\%$, 45rpm: $\pm 0.09\%$	
Signal to noise ratio	Mechanical noise: - 39 dB Electrical noise: -65dB	
Downforce range	0 - 25 mN	
Tonearm	9" straight shape massive aluminium construction	
Supplied counterweights	no. 82, weight 114g (± 1 g), for cartridges from 5 to 13 g	
Effective tonearm mass	14g	
Effective tonearm length	230mm (tonearm mounting distance 212mm)	
Overhang	18mm	
Power requirement	15V 0.8A	(Adaptor supplied)
Consumption	<0.25 Watts 5 Watts	standby maximum
Adaptor mains voltage	90-264 VAC	47-63Hz
Weight		
Unit only, unboxed	6 kg	(13 ^{1/5} lbs)
In shipping carton	8 kg	(17 ^{3/5} lbs)
Dimensions		
Width	482 mm	(19")
Height (including feet)	100 mm	(4")
Depth (front to back) Inc. terminals	342 mm	(13 ^{1/2} ")
Standard accessories	Audio Technica AT95E or similar cartridge (fitted) Universal 15V DC power supply White cotton gloves Felt mat Hex Allen key 1.5mm (for counter weight adjustment) Hex Allen key 3.0mm (for vertical tracking adjustment) Plastic tool for speed change Cinch cable with grounding cable Plastic single adapter for "large hole" singles Stylus pressure gauge – white plastic instrument with mN scale	

WARNING:

ANY MODIFICATIONS TO THIS PRODUCT NOT EXPRESSLY APPROVED BY MUSICAL FIDELITY WHO IS THE PARTY RESPONSIBLE FOR STANDARDS COMPLIANCE COULD VOID THE USER'S AUTHORITY TO OPERATE THIS EQUIPMENT

Musical Fidelity reserves the right to make improvements which may result in specification or feature changes without notice. E+OE.



Round Table Record Player

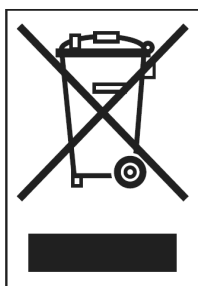

DISPOSAL

The crossed out wheeled bin label that appears on the back panel of the product indicates that the product must not be disposed of as normal household waste. To prevent possible harm to the environment please separate the product from other waste to ensure that it can be recycled in an environmentally safe manner. Please contact local government office or retailer for available collection facilities.



DISPOSITION

La poubelle sur roulettes barrées X, qui apparaît en logo sur le panneau arrière du produit, indique que celui-ci ne doit pas être traité comme un déchet domestique commun. Afin de protéger l'environnement, ce produit électronique devra être géré séparément et donc recyclé selon les nouvelles normes Européennes Rohs concernant les déchets d'appareils électroniques. Prière de contacter les services concernés gouvernementaux ou votre point de vente pour l'élimination et l'enlèvement de déchets électroniques équipés de composants électroniques.



DISPOSAL

La etiqueta cruzada hacia fuera del compartimiento que aparece en el panel trasero del producto indica que el producto no se debe reciclarse como basura normal de la casa. Para prevenir daños posible al ambiente separe por favor el producto de otra basura para asegurarse de que puede ser reciclada de una manera ambientalmente segura. Entre en contacto por favor a su oficina gubernamental local o a su minorista para las instalaciones disponibles de la colección.



RIFIUTI

L'etichetta del cassonetto barrato riportato sul retro dell'apparecchio indica che il prodotto non deve essere smaltito tramite la procedura normale di smaltimento dei rifiuti domestici. Per evitare eventuali danni all'ambiente, separare questo prodotto da altri rifiuti domestici in modo che possa venire riciclato in base alle procedure di rispetto ambientale. Per maggiori dettagli sulle aree di raccolta disponibili, contattate l'ufficio govenativo locale od il rivenditore del prodotto.



FACHGERECHTE ENTSORGUNG:

Das auf der Geräterückseite angebrachte Label deutet darauf hin, dass das Produkt nicht mit konventionellem Hauskehricht entsorgt werden darf. Um Schäden und Verschmutzungen an Umwelt und Mensch zu vermeiden, muss das Produkt fachgerecht entsorgt und von anderem Abfall getrennt werden. Wenden Sie sich bei Fragen hierzu an Ihren Fachhändler oder an eine öffentliche Informationsstelle.



AFVAL

Het label op de achterzijde van dit apparaat, een afvalbak op wielen met een kruis doorgehaald, geeft aan dat dit apparaat niet samen met gewoon huishoudafval mag worden weggegooid. Om mogelijke schade aan onze leefomgeving te voorkomen dient dit apparaat, gescheiden van gewoon huishoudelijk afval, te worden afgevoerd zodat het op een milieuvriendelijke manier kan worden gerecycled. Neem voor beschikbare inzamelplaatsen contact op met uw gemeentelijke reinigingsdienst of met uw elektronica leverancier.



HÄVITTÄMINEN

Yliüksattua jäteastiaa kuvaava tarra tuotteen takalevyssä kertoo, että tuotetta ei saa käsitellä normaalina talousjätteenä. Ympäristön suojelemiseksi on tuote pidettävä erillään muusta jätteestä ja se on kierrätettävä ekologisesti kestäväällä tavalla. Ota yhteyttä laitteen myyjään tai Pirkanmaan Ympäristökeskukseen lähimmän kierrätyskeskuksen löytämiseksi.



AFSKAFNING

Logoet med en skraldespand med kryds over på bagsiden af apparatet indikerer at dette produkt ikke må kasseres som normal husholdningsaffald. For at forebygge mulig skade på miljøet, bedes De separere dette produkt fra andet affald, og sikre at det bliver genbrugt på en miljørigtig måde. Kontakt venligst de lokale myndigheder eller din forhandler for oplysning om nærmeste tilgængelige opsamlingssted for elektronikaffald.



ΔΙΑΔΙΚΑΣΙΑ ΑΠΟΡΡΙΨΗΣ

ΤΟ ΣΗΜΑ ΜΕ ΤΟΝ ΔΙΑΓΕΓΡΑΜΜΕΝΟ ΤΡΟΧΗΛΑΤΟ ΚΑΔΟ ΑΠΟΡΡΙΜΑΤΩΝ ΣΤΗΝ ΠΙΣΩ ΟΨΗ ΤΟΥ ΜΗΧΑΝΗΜΑΤΟΣ ΔΗΛΩΝΕΙ ΟΤΙ ΤΟ ΠΡΟΙΟΝ ΑΥΤΟ ΔΕΝ ΠΡΕΠΕΙ ΝΑ ΔΙΑΧΕΙΡΙΣΘΕΙ ΣΑΝ ΣΥΝΗΘΙΣΜΕΝΟ ΟΙΚΙΑΚΟ ΑΠΟΒΛΗΤΟ. ΠΡΟΣ ΑΠΟΦΥΓΗ ΕΝΔΕΧΟΜΕΝΗΣ ΕΠΙΒΑΡΥΝΣΗΣ ΤΟΥ ΠΕΡΙΒΑΛΛΟΝΤΟΣ, ΞΕΧΩΡΙΣΤΕ ΤΟ ΠΡΟΙΟΝ ΑΠΟ ΤΑ ΑΛΛΑ ΑΠΟΡΡΙΜΑΤΑ ΩΣΤΕ ΝΑ ΕΞΑΣΦΑΛΙΣΘΕΙ Η ΑΝΑΚΥΚΛΩΣΗ ΤΟΥ ΜΕ ΤΟΝ ΠΡΕΠΟΝΤΑ ΤΡΟΠΟ. ΠΑΡΑΚΑΛΟΥΜΕ ΝΑ ΕΠΙΚΟΙΝΩΝΗΣΕΤΕ ΜΕ ΤΗΝ ΤΟΠΙΚΗ ΥΠΗΡΕΣΙΑ ΑΝΑΚΥΚΛΩΣΗΣ Η ΜΕ ΤΟ ΚΑΤΑΣΤΗΜΑ ΑΓΟΡΑΣ ΓΙΑ ΠΕΡΙΣΣΟΤΕΡΕΣ ΛΕΠΤΟΜΕΡΕΙΕΣ.