

## E60 CD PLAYER

### *INSTRUCTIONS FOR USE*

*Thank you for purchasing the Musical Fidelity Elektra E60 CD Player. Used properly and carefully, it should give you many years of outstanding musical reproduction.*

*The E60 is the result of many years painstaking research and development. It is designed for ultra-high definition performance.*

*Aesthetically, the E60 is a perfect match for the Elektra E10 or E101 amplifiers and the E50 tuner. Together, they form one of the finest hi fi systems that you can own today.*

*Dust regularly with a soft duster or soft brush but do not use cleaning or polishing agents - they may harm the surface finish.*

*If you have any questions about anything in your audio system, please consult your dealer who is there to help and advise you.*



## IMPORTANT!

This unit is supplied in the UK with a mains lead fitted with a moulded 13 amp plug. If, for any reason, you need to cut off this plug, please observe the following safety precautions.

Please dispose of the cut-off plug safely. It ***must not*** be plugged into a mains power supply.

The wires in the mains lead supplied with this appliance are coloured in accordance with the following code:

Green and yellow.....Earth  
Blue.....Neutral  
Brown.....Live

### WARNING - THIS APPLIANCE MUST BE EARTHED.

As the colours of the wires of the mains lead of this appliance may not correspond with the coloured markings identifying the terminals in your plug, proceed as follows:

- The wire which is coloured green-and-yellow must be connected to the terminal in the plug which is marked with the letter E or coloured green or green-and-yellow, or by the earth symbol  .
- The wire which is coloured brown must be connected to the terminal which is marked with the letter L or coloured red.
- The wire which is coloured blue must be connected to the terminal which is marked with the letter N or coloured black.
- If connecting to a BS1363 plug, a 10 amp fuse must be used.

### WARNING - RADIO FREQUENCY INTERFERENCE

This hi-fi product has been tested to ensure that its operation will not be adversely affected by normal background levels of Radio Frequency Interference (RFI). It is possible that if this product is subjected to abnormally high levels of RFI the unit may be susceptible and not perform as expected. In the unlikely event of this happening on a regular basis, please contact Musical Fidelity's Customer Service Department.

The unit has also been tested to ensure that it does not radiate excessive levels of RFI that could affect other pieces of electronic or electrical equipment.

The electronics in modern hi-fi equipment is complex and hence may be damaged by lightning. It is possible that during electrical storms the operation of some equipment may be adversely affected. For complete protection of your hi-fi system during such storms, mains plugs should be removed and aerial leads disconnected.

Always ensure that when disconnecting and reconnecting your hi-fi equipment the mains supply is switched off.

To comply with North American regulations this equipment has been tested and found to comply with the limits for a Class B digital device, pursuant to part 15 of the FCC rules. These limits are designed to provide reasonable protection against harmful interference in a residential installation.

**WARNING - ANY MODIFICATIONS OR CHANGES TO THIS UNIT NOT EXPRESSLY APPROVED BY MUSICAL FIDELITY WHO ARE THE PARTY RESPONSIBLE FOR COMPLIANCE COULD VOID THE USER'S AUTHORITY TO OPERATE THIS EQUIPMENT.**

This equipment generates, uses and can radiate radio frequency energy and, if not installed and used in accordance with the instructions, may cause harmful interference to radio communications. As it cannot be guaranteed that interference will not occur in a particular installation the user is encouraged to try to correct any interference experienced, for instance to radio or TV broadcasts, by one or more of the following measures.

- Identify the source of interference, turn off the CD player, check whether the interference disappears.
- Reorientate or relocate the receiving aerial.
- Increase the separation between the CD player and receiver.
- Connect the CD player into a mains outlet on a different circuit from the receiver.
- Consult a dealer or experienced TV/radio technician for help.

**WARNING - THIS CD PLAYER CONTAINS A LASER.**

This equipment contains a laser which emits invisible radiation. Only a qualified service person should remove the cover or attempt to service this device due to possible eye injury.

Optical pickup type: KSS-150A / KSS-210A  
Manufacturer : Sony Corporation  
Laser output : Less than 0.4mW on the objective lens  
Wavelength : 760 - 800 nm

## CLASS 1 LASER PRODUCTS

This CD player has been designed and manufactured according to FDA regulations "title 21, CFR, chapter 1, subchapter J, based on the Radiation Control for Health and Safety Act of 1968", and is classified as a Class 1 laser product. There is no hazardous radiation during normal use because invisible radiation emitted inside this product is completely confined within the protective housing. However you must comply with the following important cautions.

### CAUTION !

- **THIS CD PLAYER OPERATES WITH INVISIBLE LASER LIGHT. WHEN THE PLAYER OPERATES LASER LIGHT IS RADIATED INTERNALLY. DO NOT REMOVE THE PROTECTIVE HOUSINGS.**
- **USE OF CONTROLS OR ADJUSTMENTS OR PERFORMANCE OF PROCEDURES OTHER THAN THOSE SPECIFIED HEREIN MAY RESULT IN HAZARDOUS RADIATION EXPOSURE.**
- **IF THIS PRODUCT DEVELOPS A FAULT PLEASE CONTACT YOUR AUTHORISED MUSICAL FIDELITY SERVICE AGENT. DO NOT ATTEMPT TO SERVICE IT YOURSELF AND DO NOT CONTINUE TO USE THIS PRODUCT IN A FAULTY STATE.**

### WARNING AND INFORMATION LABELS:

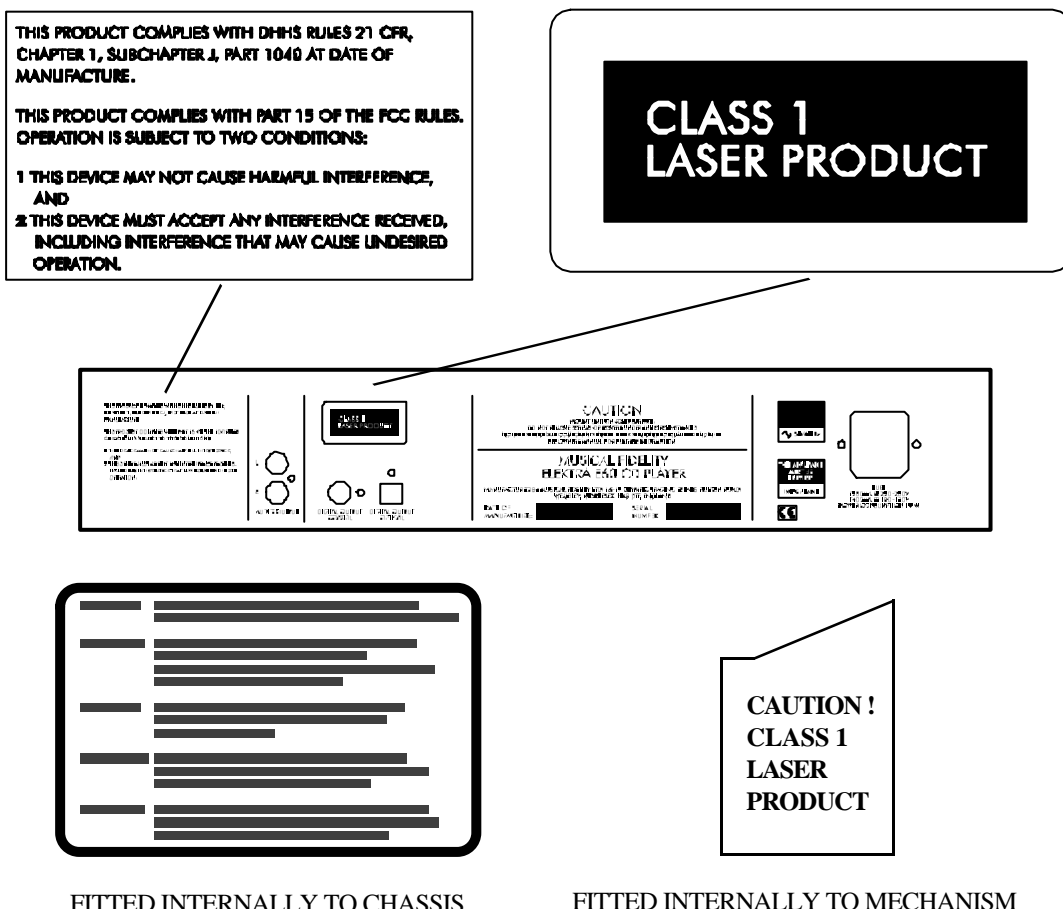

FITTED INTERNALLY TO CHASSIS

FITTED INTERNALLY TO MECHANISM

# FACILITIES AND CONNECTIONS

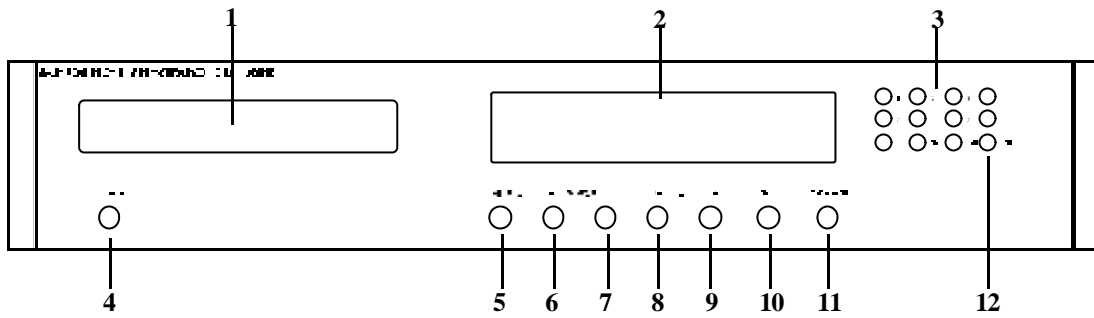

## Front Panel/Remote Control

- 1 CD transport drawer
- 2 CD player display
- 3 1-10, +10 for direct track selection
- 4 POWER mains switch to switch the CD player ON/OFF
- 5 OPEN/CLOSE to open and close the CD transport drawer
- 6 SEARCH fast reverse
- 7 SEARCH forward search
- 8 SKIP reverse track selector
- 9 SKIP forward track selector
- 10 STOP to stop CD playback
- 11 PLAY /PAUSE to start CD playback/to stop and restart CD playback
- 12 EDIT selects the recording time on the cassette

- 22 ONE/ALL to select repeat mode
- 23 PROGRAM to enter tracks for programmed playback
- 24 CALL to check programmed tracks
- 25 CLEAR to clear programme memory
- 26 A/B to select continuous play mode
- 27 RANDOM to play back tracks in random order
- 28 INTRO to play beginning of each track

## Rear Panel

- 13 LINE OUTPUT
- 14 DIGITAL OUTPUT
- 15 IEC type mains inlet

## Remote Control

- 16 REVERSE tracks played back in reverse order
- 17 AUTO SPACE playback with 4 seconds pause between each title
- 18/19 INDEX to select an index point
- 20 TIME to change time display
- 21 DIMMER to change brightness of LCD display

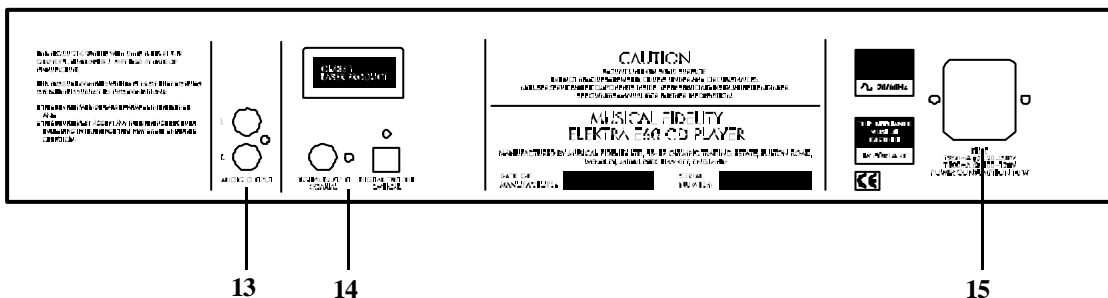
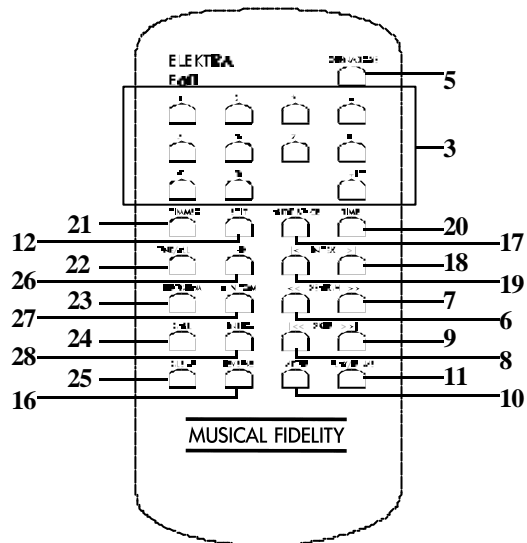

## INSTALLATION PRECAUTIONS

Your new E60 is designed and built to provide trouble-free performance but it is sensible to observe a few precautions. Please ensure that you have complied with them before you connect any AC power to your system. Retain this guide for future reference.

- ☑ **Heed all warnings on the back of the unit.**
- ☑ **Place your Elektra E60 where there is adequate ventilation.**
- ☑ **Only connect the unit to a power supply of the type marked on the back of the unit.**
- ☑ **Position the power supply lead and signal interconnect leads where they are not likely to be walked on or trapped by items placed on them.**
- ☑ **Do not use near water.**
- ☑ **Do not place the CD Player near direct heat sources such as radiators or other equipment that produces heat.**
- ☑ **Do not remove any covers or try to gain access to the inside. The warranty will be invalid if the unit has been tampered with. There are no user adjustments within. Refer all service work to an authorised Musical Fidelity agent.**

The remote control enables you to activate the main functions of the stereo system from the comfort of your armchair. Several of the functions described in this manual are only available on the remote handset. Identical inscriptions on the remote control and CD player denote identical functions. The following should be noted when operating the player using the remote control: - Point the remote control (transmitter) towards the display on the player. - Visual contact must exist between the transmitter and receiver. - If the range of the remote control decreases dramatically, replace the batteries with new ones.

### **Before Switching on the Stereo System**

Please read carefully the instructions on the following pages. The functional arrangement of the controls makes the stereo system easier to operate. To make use of all the options available. You should nevertheless study these instructions carefully.

**Important! Unauthorised opening of the equipment will invalidate any warranty claims.**

**Note:** To help your dealer identify your CD player if after-sales service is required, please quote the serial number written on the rear panel of the unit.

## BEFORE YOU SWITCH ON

*Follow this routine before you listen for the first time, and each time you change any connections.*

- 1 *Check all the connections to the E60 and your audio system.*
- 2 *Then check again.*
- 3 *Turn the volume control of your amplifier to zero ( Fully anti-clockwise).*
- 4 *Select "CD/AUX" input via your amplifier.*
- 5 *Now you can switch on the power, insert your CD, and carefully advance the volume control of your amplifier to the level you desire.*
- 6 *Enjoy the music.*

## INSTALLATION

Take the individual housing situation into consideration (arrangement of mains wall sockets etc.).

Place your set on a stable, horizontal, vibration-free surface where there is no risk of the set falling over or being subjected to vibrations. This could otherwise damage the sensitive electronics inside.

Any heat generated by the set must be free to escape. Any heat buildup may cause the electronic components to malfunction or fail.

Therefore, if you place your set in a cabinet or on a shelf, make sure that there is enough room for heat to dissipate and air to circulate around the set. If in doubt, ask your dealer.

Avoid placing your set next to radiators or in sunlight where additional heat could affect the set.

Protect your set from humidity. Do not place your set under a window, otherwise, in the worst case, rain could fall onto the set. Do not place any containers

filled with water on the set, e.g. flower vases, potted plants, etc. If the container should fall over and water enters the set, damage is unavoidable.

However, if water does enter the set, immediately pull out the power plug and inform your dealer. He will then check the set before you use it again.

**- Liquid entering the set could cause dangerous short-circuits which, in the worst case, could cause a fire.**

If you move your set from a cold place to a warm place, leave the set switched off for a few hours. Condensation could form inside the set.

## CLEANING

Before cleaning the set, switch off the main switch on the set. Clean the housing of the set and the remote control unit using a moist cloth. Do not use any solvents, white spirits, thinners, etc. Otherwise, they could damage the surface of the unit.

## AUDIO CONNECTION

The CD player is connected to the amplifier (CD/tape socket) by audio cable with RCA type (phono) connectors. This is connected to the LINE OUTPUT sockets. Please see your authorised dealer if an adapter cable is necessary for connection to the amplifier. Make sure that you plug in the leads correctly to the right and left channels. Alternatively, you can use the DIGITAL OUTPUTS for connection to an outboard Digital-to-Analogue converter or digital amplifier.

## NOTES ON USING COMPACT DISCS

Always hold discs by the edges and make sure they remain clean. Do not touch the shiny rainbow surface. Do not stick any paper or adhesive tape on the side of disc with the label. Keep discs away from direct sunlight and heat sources, such as radiators. Do not leave discs in a car which is parked

in direct sunlight, since the temperature inside the car can become extremely high. Clean discs with a cloth before playing them. Do not use any solvents such as benzene, thinners, commercially available cleaners or antistatic spray intended for analogue discs to clean your compact discs. After playing, store a disc in its case again.

## MOISTURE

If the unit is exposed to extreme temperature fluctuations, moisture will form inside it. Condensation will form on the lens and on other parts inside the unit. If the CD player is operated under these conditions, the laser beam will not be able to read the signals. In this case you should remove the CD, close the disc compartment, set the unit to Stand-by and leave it alone for around 1 hour. The moisture will then have evaporated and you will be able to use your CD player again.

## INSERTING AND REMOVING COMPACT DISCS

After switching on the CD player, the following is displayed on the display unit:



If a disc is not inserted now, the display below will appear after approximately 5 sec.:



Press the "OPEN/CLOSE" button to open the transport drawer to insert or remove the CD. The following message appears in the display unit:



Then insert the CD with the labelled side facing upwards. You can also play CD singles without an adapter. Perfect functioning of the CD player is only ensured with compact discs whose playing time does not ex-

ceed the 74 minute specified limit. Press the OPEN/CLOSE button to close the transport drawer again. The following message appears in the display panel:



The CD system scans the contents of the disc as soon as the disc compartment is closed. The number of tracks on the CD then appears in the display unit and the total playing time of the CD. All numbers of the CD tracks (max. 20) appear in the calendar display.



## PLAYING THE WHOLE DISC

Once the compact disc player has read and displayed the contents of the CD, the CD is ready for playing. Briefly press the PLAY/PAUSE button to start play. An arrow appears in the display unit to indicate playback.

During playback the number of the current selection and its elapsed playing time and INDEX are displayed:



*Note:* You can see on the CD cover whether the disc has an index or not.

If a track is played, its number disappears from the calendar display. When all tracks on the CD have been played, playback stops and this indication appears in the display:



*Note:* - if you insert a CD the wrong way up, i.e. with the label side facing downwards, the following will appear in the display unit:



When PLAY/PAUSE is pressed after inserting the CD, the disc will begin to play automatically immediately after the



disc slot has been retracted.

## PLAYBACK OF A SELECTED INDEX POINT

If the various tracks of the CD have a call up index, you can select a particular index during playback.

Press the appropriate INDEX key until the desired index appears on the display, e.g.:



## CONTINUOUS PLAY

Continuous play provides you with the option of playing a certain part of the disc over and over again.

*Example:* You want to listen to a certain section of a track several times in a row. After pressing the PLAY/PAUSE key you can select the beginning of the desired section by pressing the A-B button.

You can use the display unit to help you find the desired section or you can set it by ear. When you reach the desired point, press button A-B. The display unit will show the symbol A- and the flashing letter B.



If the scanner has reached the end of the desired section, press A-B again. The letters A-B will remain illuminated in the display unit. Now the set selection will be repeated until the continuous play is switched off by pressing button A-B again or by pressing buttons STOP, INTRO or RANDOM. The unit will now return to normal operation or to the function corresponding to the button pressed.

## PLAYBACK TIME

You can select the following display modes by pushing the TIME push-button several times.

- the length of time the track has played
- the remaining play time of the track

- the total remaining play time of the CD or of the programming
- the length of time the CD has played

## RANDOM PLAYBACK

If RANDOM is pressed the tracks on the discs are not played in consecutive order but in random order. With this function, the individual tracks are played in a different order each time the disc is played. The word RANDOM appears in display unit to provide a visual reminder that the random function has been activated.



Press the RANDOM button to switch off the random function.

## PAUSE

Press the PLAY/PAUSE" button in order to stop for a moment during play. The message below appears in the display unit:



Press Pause again to restart play.

## TRACK SELECTION

The SKIP buttons can be pressed to select a desired track in either direction. Press one of the buttons and hold it down until the desired track appears in the display unit.

>>| = forwards

|<< = backwards

The display unit provides additional information.

Select the track using the numeric push-buttons. To select a two-digit track, select the tens digit via the "+10" push-button. Select single digits by pressing the numeric push-buttons within 4 seconds. The display serves for check purposes.

## SEARCH

You can use the SEARCH buttons to start a search during playback. This permits you to locate particular passages at

high speed. The playback mode is not switched off.

When you release the button again, the unit will return to the normal playback mode.

## TITLE SEARCH

Press INTRO to play back the first ten seconds of each title on the inserted CD disc and/or of the programmed titles for about 10 seconds.



Press INTRO lightly again and the CD player will playback the desired title.

## REPEAT

By pressing the ONE/ALL button once, you can play the track you have just heard over and over again. The word REPEAT ONE appears in the display unit at the same time.



If you press the ONE/ALL button twice, you can play the entire disc or the programmed selections over and over again. The word ALL appears in the display unit.

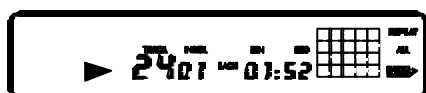

You can switch off the repeat function by pressing the ONE/ALL button again.

## EDIT

If you want to pre-program the recording time when you record to a cassette, press the button marked EDIT. The CD player automatically selects a CD track which can be recorded in the time you have pre-programmed. Prepare your stereo set for recording according to the steps described in the operating instructions.

1. Insert a CD. The number of titles in addition to the total playback time are

displayed on the display unit.

2. Then press the EDIT key and by using the "1 +10" keys you can change the length of the recording time on both sides of the tape, e.g. the duration of a 30-minute recording (press "+10" 3 times and then "0")



3. Now the tracks that will be recorded on side A during time set will appear. Following this the tracks that can be recorded during the time set on side B will appear. The CD recorder then goes into the Pause position.

4. After pressing PLAY/PAUSE, the CD player starts to playback the titles that can be recorded in the pre-programmed period of time.

5. After playing back these titles, the real recording time for side B is displayed for the same period as has been selected for side A, e.g.:



Now turn the cassette in the cassette deck to the other side and set the cassette recorder to recording mode. Press PLAY/PAUSE to playback the titles for side B.

*Note:* The recording time of side B can no longer be changed.

CD playback takes place with the Auto Space function, i.e. with a pause of 4 seconds between each track. The function is useful for tape recordings when the recorder is equipped with an Automatic Track Search facility.

## PROGRAM MEMORY

The built-in program memory allows you to store up to 32 tracks and to play them back in whatever order you wish. If you should accidentally enter more than 32 tracks, the memory will stop storing tracks after it has reached 32. It is possible to store a track more than once in the same program if desired.

*Example:* You wish to listen to tracks 14, 2, 9, 9,12 and 22 in that order on a disc with 24 tracks. When the scanner has read the disc, 24 and the total playing time will appear in the display unit.



Press the PROGRAM push-button to switch over to programming mode. Press the SKIP push-button until the desired track number appears in the display.



Track 14 can be stored under programme number 1 by pressing the PROGRAM button. The message below appears in the display unit:



Then select by pressing the SKIP button the 2nd track and store it by pressing the 'PROGRAM' button.



The playback time of the newly programmed title is added to the total playback time programmed on the MIN and SEC display.

You can then store all the remaining tracks in the same way. If you want to save a track twice in succession, reselect the track and save it again by pressing the program button.

Once you have stored tracks 12 and 22 according to the same procedure, briefly press the PLAY/PAUSE button. The programmed tracks are then played.

When all programmed tracks have been played, the CD player stops. You can play the same tracks again by pressing the PLAY/PAUSE button.

By pressing the CALL push-button repeatedly, you can check which track is saved in which position.

*Note:* The entire program will be

cleared as soon as you open the disc compartment.

## STOP/CLEAR

You can stop play by pressing the STOP button once. A track is cleared in the opposite direction each time you press the CLEAR push-button.

# TROUBLESHOOTING

Basic troubleshooting of a CD player is similar to troubleshooting of any other electrical or electronic equipment. Always check the most obvious possible causes first. To give you a few ideas of what to look for, check the following:

| <b>Problem</b>                                     | <b>Probable Cause</b>                         | <b>Remedy</b>   |
|--|---|---|
| <b>No power when POWER is pressed</b>              | Power plug not inserted securely              | <i>Plug in securely</i>   |
| <b>No playback when disc is loaded</b>             | Disc loaded with label side down              | <i>Load with label side up</i>  |
|  | Disc dirty                                    | <i>Clean disc surface</i>   |
| <b>No audio output (or too low level output)</b>   | Connection to stereo system is incorrect      | <i>Check connections</i>  |
| <b>Playback starts when power is switched on</b>   | Compact disc left on the disc tray            | <i>Remove the disc from the player unless timer playback is required</i>    |
| <b>Mistracking (sound jumping)</b>                 | Player receiving vibration or shock           | <i>Change the installation position of the player</i>                       |
|  | Disc dirty                                    | <i>Clean disc surface</i>   |
| <b>Hum</b>   | Signal connection plug not connected securely | <i>Reconnect plug securely</i>  |
| <b>Noise in tuner</b>                              | Player too near tuner                         | <i>Keep a reasonable distance between them or switch off player's power</i> |
| <b>Remote control unit operation is impossible</b> | Player's POWER switch set to OFF              | <i>Set switch to ON</i>   |
|  | Batteries not inserted in remote              | <i>Insert batteries</i>   |

**Remember: the most vulnerable part of a CD playing system is the disc itself. Despite various popular press statements to the contrary, CDs are not indestructible, nor are they all perfect. The most likely cause of non-playing of a disc is that the disc is faulty, either due to imperfect pressing, scratches or simple dirt. If the player always plays discs which are in good condition and within the 74 minute time limit stated in the original CD specification, the fault is certainly with the disc.**

If none of these actions effect a cure, please contact your dealer, or an authorised Musical Fidelity service agent. Remember, never open the case of the E60 yourself, as this will invalidate the guarantee.

## E60 CD Player

### AUDIO

|                     |                                  |
|---------------------|----------------------------------|
| Frequency response  | 20 - 20,000Hz +/-1dB             |
| S/N ratio           | 105dB                            |
| Dynamic range       | Better than 95dB (1 kHz)         |
| Harmonic distortion | 0.009% (1 kHz)                   |
| Wow and flutter     | Not measurable (Quartz accuracy) |
| Channel separation  | Better than 92dB (1 kHz)         |
| Output: analog      | 2.0V rms                         |
| digital             | 0.5Vp-p/75 ohm (Coaxial)         |
| D/A converter       | “Bitstream” conversion           |
| Digital filter      | 8-times oversampling             |
| Analog filter       | 4 pole CHV filter                |

### PICK-UP

|                |  |
|----------------|--|
| Type           | Objective lens drive, optical 3 beam laser pick-up |
| Objective lens | 2 dimensional parallel drive                       |
| Laser type     | GaAlAs type semiconductor laser                    |
| Wavelength     | 760-805 nm   |

### GENERAL

|                      |   |
|----------------------|---|
| Power requirements   | 100/115/230V AC 50/60Hz<br>Factory preset for country |
| Power consumption    | 10 Watts  |
| Dimensions           | 440 x 95 x 340mm (W x H x D)<br>Height includes feet  |
| Standard accessories | Remote Control Unit Battery 2 x (SUM-4, “AAA”, “R03”) |



*Musical Fidelity reserves the right to make improvements which may result in specification or feature changes without notice.*