

kW Hybrid Line Preamplifier

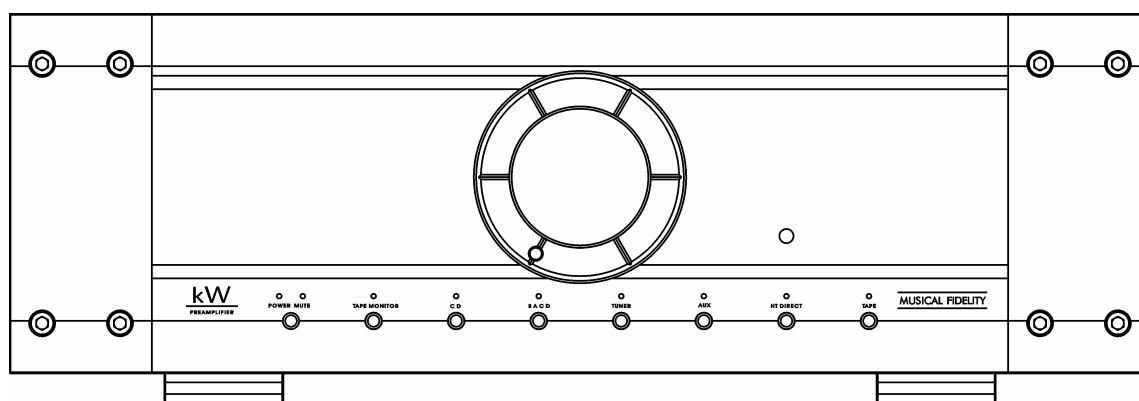

INSTRUCTIONS FOR USE

Thank you for purchasing the Musical Fidelity kW Hybrid Line Preamplifier.

Used properly and carefully, it should give many years of outstanding musical reproduction.

Aesthetically, the kW Hybrid Line Preamplifier is a perfect match for the kW 750 Power amplifier, kW Phono and the kW SACD player.

Together they form one of the finest hi-fi systems available.

Dust regularly with a soft duster or soft brush, but be careful when using cleaning or polishing agents - they may harm the surface finish.

If you have any questions about your audio system, please consult your dealer who is there to help and advise.

MUSICAL FIDELITY

SAFETY INFORMATION

IMPORTANT! (*U.K. only*)

This unit is supplied in the U.K. with a mains lead fitted with a moulded 13 amp plug. If, for any reason, you need to cut off the plug, please remove the fuse holder and dispose of the plug safely, out of reach of children. **It must not be plugged into a mains outlet.**

The wires in the mains lead supplied with this appliance are coloured in accordance with the following code:

Green and yellow.....Earth
Blue.....Neutral
Brown.....Live

WARNING - This appliance must be earthed

As the colours of the wires of the mains lead of this appliance may not correspond with the coloured markings identifying the terminals in your plug, proceed as follows:

The wire which is coloured green-and-yellow must be connected to the terminal in the plug which is marked with the letter E or coloured green or green-and-yellow, or by the earth symbol: 

The wire which is coloured brown must be connected to the terminal which is marked with the letter L or coloured red.

The wire which is coloured blue must be connected to the terminal which is marked with the letter N or coloured black.

If connecting to a BS1363 plug, a 13 amp fuse must be used.

WARNING:

Any modifications to this product not expressly approved by Musical Fidelity who is the party responsible for standards compliance could void the user's authority to operate this equipment.

GENERAL ADVICE

INSTALLATION PRECAUTIONS and USER INFORMATION

Your new kW Hybrid Line Preamplifier is designed and built to provide trouble-free performance, but as with all electronic devices it is necessary to observe a few precautions:

Heed all warnings shown on the back of the product.

Only connect the pre-amplifier to a mains outlet having the same voltage as marked at the back of the unit.

Always ensure that when disconnecting and reconnecting your audio equipment the mains supply is switched off.

Position the mains lead and signal interconnects where they are not likely to be walked on or trapped by items placed on them.

Do not use near water, or place water-filled containers on the preamplifier, for example, a flower vase or potted plants. **If water does spill inside, immediately pull out the mains plug from the wall socket and inform your dealer, who should then check the unit before further use. Entry of liquid into the preamplifier is dangerous, and may cause electric shock or fire hazard.**

Do not place the unit near direct heat sources such as radiators, direct sunlight or other equipment.

Do not remove any covers or try to gain access to the inside. There are no internal adjustments or fuses you can replace yourself. Refer all service work to an authorised Musical Fidelity agent.

Note: Unauthorised opening of the equipment will invalidate any warranty claim.

Dust regularly with a soft cloth or soft brush but be careful when using cleaning or polishing agents - they may harm the surface finish.

The electronics in modern hi-fi equipment is complex and may, therefore, be adversely affected or damaged by lightning. For protection of your audio system during electrical storms, remove the mains plugs and disconnect any aerial lead.

If after-sales service is required, to help your dealer identify the kW Hybrid Line Preamplifier please quote the serial number located on the rear panel of the unit.

RADIO FREQUENCY INTERFERENCE (R.F.I)

This product has been tested to ensure that its operation is not adversely affected by normal background levels of R.F.I., and that it does not itself generate excessive amounts of interference. However, if a problem persists, please contact your Musical Fidelity agent.

CONNECTIONS and FACILITIES

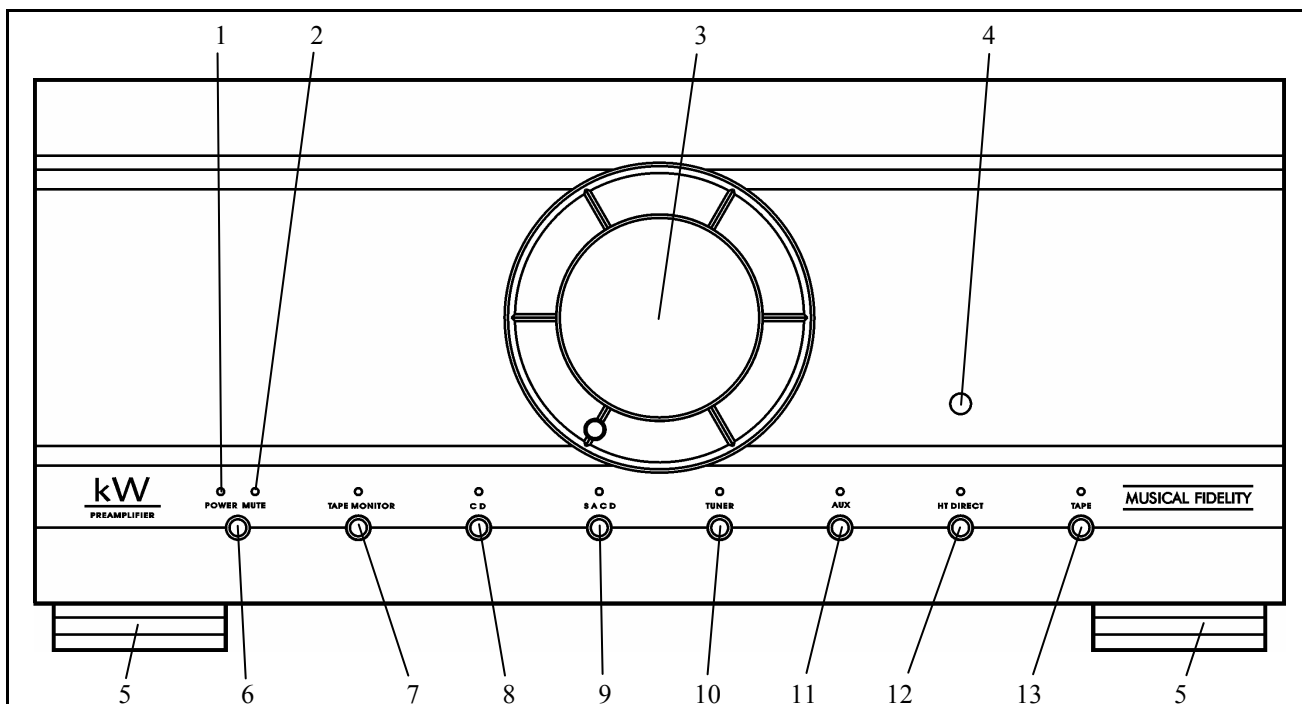

FRONT PANEL

- | | |
|---|---|
| 1 POWER on indicator LED | 7 TAPE MONITOR button and LED |
| 2 MUTE indicator LED (red) | 8 CD input select button and LED |
| 3 Volume control | 9 SACD input select button and LED |
| 4 Infra Red Receiver for remote control
(see page 5) | 10 TUNER input select button and LED |
| 5 Illuminated feet with multi-colour
indicator LEDs (see page 7) | 11 AUX iliary input select button and LED |
| 6 POWER on/off push switch | 12 Home Theatre DIRECT select button and
LED (see page 6) |
| | 13 TAPE input select button and LED |

REAR PANEL

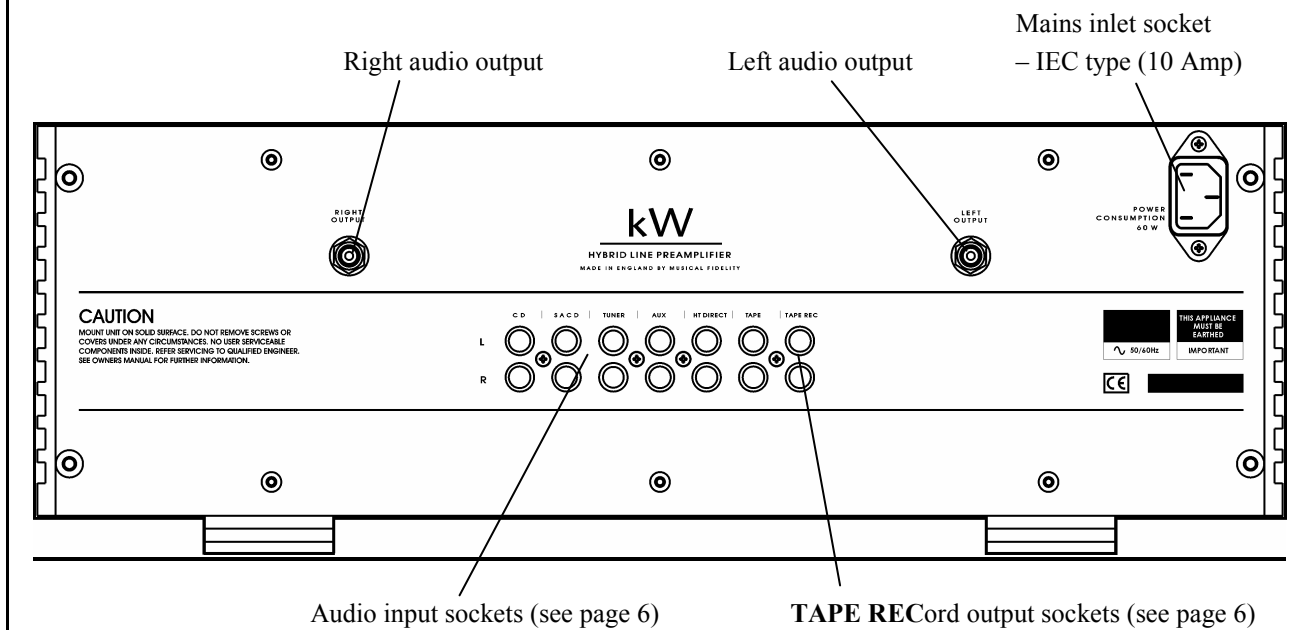

REMOTE CONTROL

The blue buttons on the remote control enable main functions of the preamplifier to be operated from a convenient distance. Remaining buttons on this universal handset are for use with other Musical Fidelity products, and have no effect on the kW Hybrid Line Preamplifier.

Equivalent buttons on the remote handset have the same functions as those on the front panel of the unit.

As the remote control uses an invisible infra-red light beam, the transmitter must be pointed directly towards the receiver window on the front of the amplifier, without visual obstruction between them.

Pressing the volume-up or -down buttons on the remote handset will turn the motorised volume control in the required direction.

Pressing the **MUTE** button disables the OUTPUT sockets, but does not affect TAPE RECORD output. A red mute LED on the front panel lights to show that the pre-amplifier is not producing an audio signal for the amplifier. Pressing the **MUTE** button again cancels mute function, and the red LED goes out.

If the range of the remote control greatly decreases, replace the batteries with new ones. Do not mix old and new batteries - two are required, type SUM-4, AAA or LR03.

Do not dispose of used batteries in a fire.

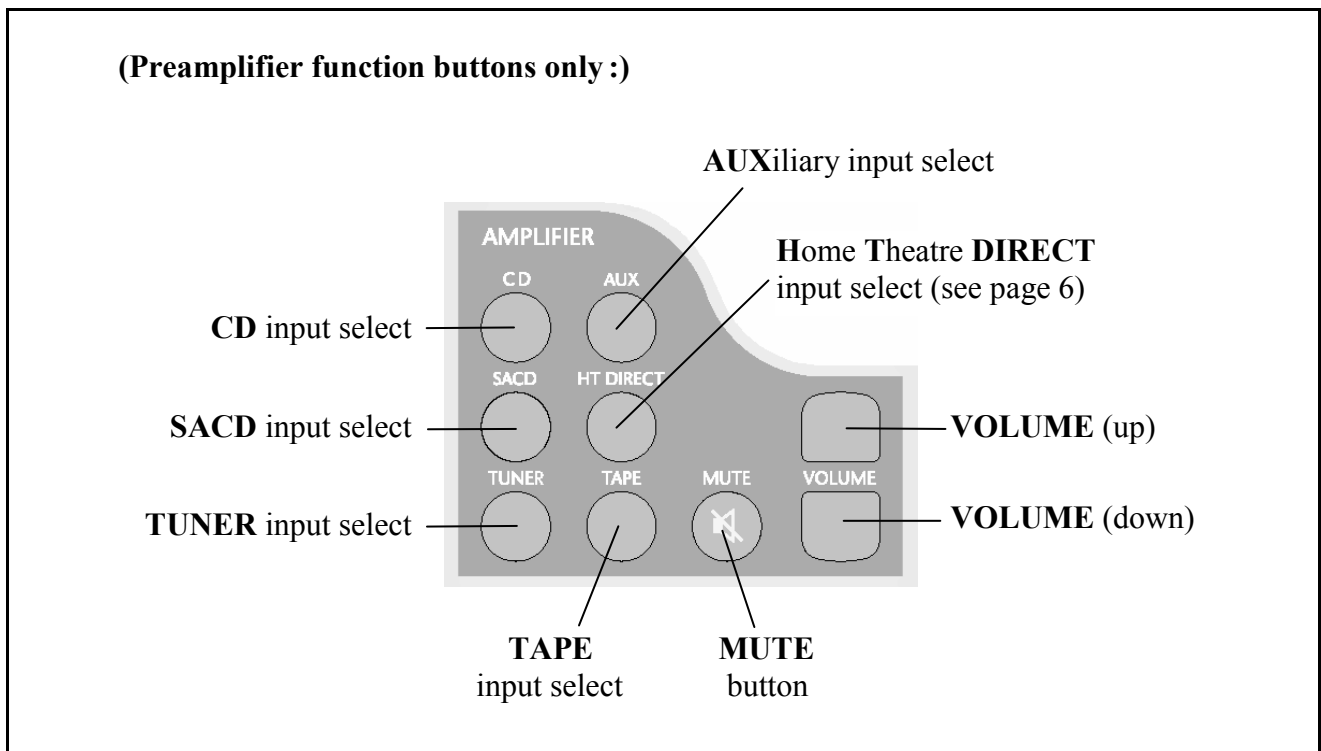

CONNECTIONS

All input, output and power connections should be made with the mains power switched OFF.

INPUT CONNECTIONS

The kW Hybrid Line Preamplifier has five “line level” inputs controlled by the internal volume setting. They all have the same input sensitivity, and are therefore suitable for use with any source component having an output of at least 300mV. The five pairs of sockets on the rear panel are marked **CD**, **SACD**, **TUNER**, **AUXiliary** and **TAPE**, corresponding with function selector buttons on the front panel.

However, the **HT DIRECT** input sockets are intended for home theatre use. When selected, they are routed inside the kW preamplifier directly to the **OUTPUT** sockets, and are not controlled by the volume adjustment.

Do not therefore connect these sockets to a source without its own volume control.

PREAMPLIFIER OUTPUT

Audio output is available from the kW Hybrid Line Preamplifier via RCA sockets on the back panel marked **LEFT** and **RIGHT OUTPUT**.

TAPE RECORDER CONNECTION

The kW Preamplifier has a single tape circuit with facilities for off-tape monitoring with 3-head tape decks (see page 7).

The tape deck's left and right line outputs are routed to the kW Preamplifier's **TAPE** (playback) input sockets, and the tape deck's line inputs are connected to the preamplifier's **TAPE RECord** (output) sockets.

BEFORE SWITCHING ON

Plug the accessory IEC mains lead into the rear panel socket, then the other end into a wall outlet.

Turn the volume control on the front panel to minimum (anticlockwise).

OPERATION

STARTING

Press the **POWER** switch button on the preamplifier front panel - the blue LED just above the button will light indicating that power is applied to the unit.

However, for about fifteen seconds no sound will be heard from your speakers, and the red MUTE LED near the power switch will light, confirming initial mute action.

During this delay period, support feet underneath the unit will also glow red, then change to yellow showing that your kW Preamplifier is ready for use. After about 35 minutes of operation, the feet colour will further change to blue.

Unless using your audio system for off-tape monitoring (see paragraph opposite) → ensure that the **TAPE MONITOR** button has not been pressed accidentally, as otherwise no sound will be heard through the speakers.

Select the required audio input source by pressing an appropriate function button on the front panel or remote control, and adjust the volume control to obtain the preferred sound level.

TAPE RECORDING

To record, simply select the required source with the input selector button on the front panel or remote control. This source will now be routed to the kW Preamplifier's **TAPE RECORD** output sockets for recording by the external tape deck. You will also be able to hear the selected source through the loudspeakers.

Note - adjustment of the volume control has no effect on the recording level.

OFF-TAPE MONITORING

In conjunction with a 3-head cassette deck, off-tape monitoring allows the user to compare recorded sound with the original whilst a recording is being made. To do this, first select the required source in the normal way and start recording.

The **TAPE MONITOR** button on the front panel can now be used to switch between the original source sound and the recorded version, allowing direct comparison. The blue LED just above the monitor button is lit when the tape monitor function is operating, confirming that the recorded sound is selected.

On some 3-head tape decks there is an additional 'tape/source' switch, which must be in the 'tape' position for the above to work.

If in doubt, please refer to your tape deck operating manual.

PROBLEMS?

Basic problem-solving with a preamplifier is similar to troubleshooting other electrical or electronic equipment. Always check the most obvious possible causes first, such as the following examples:

Problem	Probable Cause	Remedy
No power when POWER button is pressed	Mains power plug is not fully inserted into rear socket	Plug in securely
No sound	Tape monitor function has been selected (see page 7)	Switch off tape monitor
	Mute function is still active (red mute LED is still on)	Press the MUTE button on the remote control to cancel
	Wrong connections between the kW Hybrid Line Preamp and your amplifier	Check audio input lead connections
Hum	An audio connector plug is not fully pushed in.	Insert plug securely.
	Connector cable is faulty	Check that the cable outer shield (screen) connection has not become damaged or detached inside the plug
Remote control does not work	Preamplifier's POWER switch is set to off	Set switch to on
	One or more batteries fitted the wrong way round	Insert batteries correctly
	Batteries are flat	Change batteries – do not mix old and new ones
	Remote control is not pointed directly towards the front panel of the player	Ensure there is no obstruction between the remote control and preamplifier front
Remote control range has greatly reduced	Batteries are running out	Change batteries – do not mix old and new ones

If none of these actions effect a cure, please contact your dealer, or an authorised Musical Fidelity service agent. Remember, never open the case of the kW Hybrid Line Preamplifier yourself, as this will invalidate the guarantee.

kW Hybrid Line Preamplifier

SPECIFICATIONS

Output :

Voltage RMS, maximum	> 62 Volts
Peak-to-peak instantaneous output current	4.5 Amps
Impedance	< 0.5 Ohm
Frequency response	20Hz to 30kHz \pm 0.5dB

Line inputs :

Total harmonic distortion + noise, 20Hz to 20kHz	< 0.0068% (5 Volts output, maximum volume)
Signal / noise ref. 1 Volt RMS output	> 105dB ("A"-weighted, at half volume)
Input sensitivity for 1 Volt RMS output	240mV
Input impedance	47k Ohms
Gain at maximum volume	12.5dB (4.2 times)
Input overload margin	40dB
Channel separation	> 84dB 20Hz to 20kHz, maximum volume
Channel balance error	< 0.5dB typical, worst case 1.5dB with volume control at around 8 o'clock position

Inputs :

4 pairs line level RCA connectors,
1 pair (Home Theatre) direct power amplifier input
RCA connectors

Outputs :

1 pair RCA main output controlled by the volume,
1 pair RCA tape record fixed line level output.

Power requirement :

115 / 230Volts or 100 V AC 50 / 60Hz (factory pre-set),
60 Watts

Weight :

20.55 kg, 45.3 lbs unit only, unboxed
25.5 kg, 56.2 lbs in shipping carton

Dimensions :

483 mm, 19 inches wide
167 mm, 6.6 inches high including feet
450 mm, 17.7 inches deep including knob and rear terminals

Standard accessories :

IEC type mains lead (10-Amp type),
remote control (kW universal type),
2 batteries size LR03 or AAA, manganese alkaline type



*Musical Fidelity reserves the right to make improvements which
may result in specification or feature changes without notice*